

SECTION A-A

ALUMINUM STEP

NOTES:

1. ALUMINUM ALLOY SPECS.
 A. FED. SPEC. QQ-A-200/8
 B. MIN. TENSILE STRENGTH = 38,000 PSI
 C. MIN. YIELD STRENGTH = 35,000 PSI
 D. MIN. ELONGATION = 10% IN 2"
2. MIN. LOAD CAPACITY (APPLIED CENTER OF STEP).
 A. 1000 lb. WITH 6" PROJECTION FROM WALL.
 B. 1500 lb. WITH 4" PROJECTION FROM WALL.
3. WEIGHT PER STEP = 2.23 lbs.
4. STEPS TO BE PLACED BEHIND REINFORCING STEEL WHEN CONCRETE SECTIONS ARE CAST. DO NOT STAGGER.

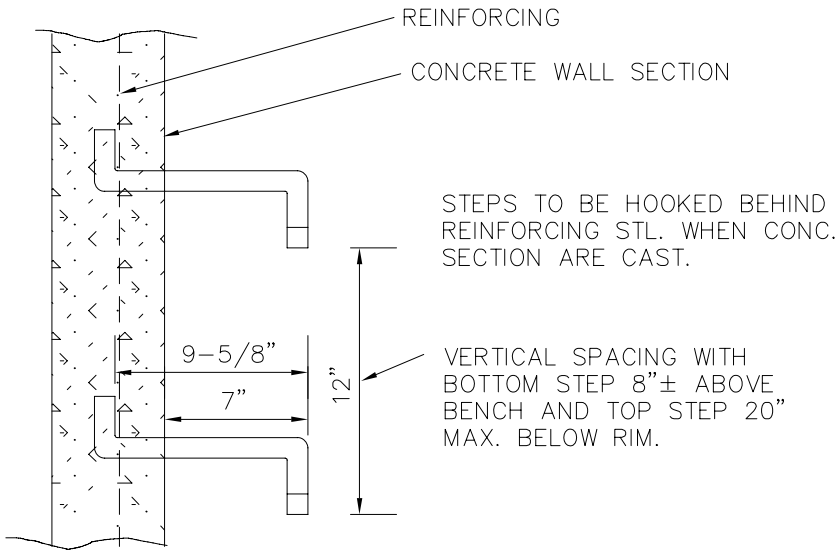

TYPICAL INSTALLATION

DATE
7/2007



PLATTE CANYON
WATER & SANITATION DISTRICT

DRAWING
D.10S

ALUMINUM
STEP