

**PLATTE CANYON
WATER AND SANITATION DISTRICT**

Fats, Oils, and Grease (FOG) Policy

(Adopted September 1, 2017)

Fats, Oils, and Grease (FOG) Policy

1.0 Purpose

The purpose of this policy is to minimize the loading of animal/vegetable fats, oils, and grease (FOG) entering Platte Canyon Water and Sanitation District's (District) wastewater collection system and the Littleton/Englewood Wastewater Treatment Plant (L/E WWTP). FOG can contribute to sewer blockages, causing sanitary sewer overflows and backups, and can interfere with equipment at the wastewater treatment plant.

2.0 Scope and Applicability

2.1 Scope

This policy encompasses the entire service area of the District including those areas located outside of the District's legal boundaries, but which discharge wastewater into the District's wastewater collection system by agreement.

2.2 Applicability

2.2.2 Nondomestic Users

This policy applies to any nondomestic user in the District's service area where preparation, manufacturing, or processing of food occurs including but not limited to restaurants, cafes, fast food outlets, pizza outlets, delicatessens, sandwich shops, coffee shops, schools, nursing homes, and other facilities that prepare, service, or otherwise make foodstuff available for consumption. These users shall install and maintain a gravity grease interceptor (GGI) and implement best management practices (BMP) as directed by the District.

2.2.3 Domestic Users

This policy does not apply to domestic users. However, the best management practices (BMPs) set forth in this policy are recommended for domestic users to assist in keeping the collection system and private sewer lines flowing freely.

3.0 Definitions and Acronyms

3.1 Definitions

Best Management Practices (BMP) - Schedules of activities, prohibitions or practices, maintenance procedures, and other management practices; it also includes treatment requirements, operating procedures, and practices to control plant site runoff, spillage or leaks, sludge or waste disposal, or drainage from raw materials storage.

Control Authority – Platte Canyon Water and Sanitation District, and the City of Littleton or their designee, including the Division.

District – Platte Canyon Water and Sanitation District

Division – The Industrial Pretreatment Division of the Littleton/Englewood Wastewater Treatment Plant.

Domestic User – Any private residential user that discharges wastes derived from ordinary living processes excluding any commercial or industrial wastes.

Fats, Oils, and Grease (FOG) – Nonpetroleum fats, oils, and grease derived from animal or plant sources.

Grease Interceptor or Gravity Grease Interceptor (GGI) – A plumbing appurtenance or appliance that is installed in a sanitary drainage system to intercept non-petroleum fats, oils, and greases (FOG) from a wastewater discharge and is identified by capacity volume and number of compartments.

Grease Trap or Hydromechanical Grease Interceptor (HGI) – A plumbing appurtenance or appliance that is installed in a sanitary drainage system to intercept non-petroleum FOG from a wastewater discharge and is identified by flow rate, and separation and retention efficiency. The design may incorporate air entrainment, hydro-mechanical separation, interior baffling, and/or barriers in combination or separately.

Inactive GGI – An existing GGI that is no longer in use

Nondomestic User – Any user that does not meet the criteria for categorization as a domestic user shall be considered a nondomestic user.

Notice of Violation (NOV) – Notice given to a user who is in violation of this policy.

Publicly Owned Treatment Works (POTW) – A publicly owned treatment works includes any devices or systems used in the collection, storage, treatment, recycling, and reclamation of sewage and any conveyances, which convey wastewater to a treatment plant.

User – Any person who contributes, causes, or permits the contribution of wastewater into the POTW

Waste Grease Bin (WGB) – Any receptacle used to store used FOG collected from fryers, grills, and other similar devices

3.2 Acronyms

BMPs – Best -Management Practices

FOG – Fats, Oils, and Greases

GGI – Gravity Grease Interceptor
HGI – Hydromechanical Grease Interceptor
L/E WWTP – Littleton/Englewood Wastewater Treatment Plant
POTW – Public Owned Treatment Works
NOV – Notice of Violation
WGB –Waste Grease Bin

4.0 Roles and Responsibilities

4.1 District

The District is responsible for implementing this policy. Duties include but are not limited to reviewing building plans, inspecting applicable users for compliance, and enforcing policy requirements.

4.2 Division

The Division has oversight authority over the District’s adoption and implementation of this policy.

4.3 Contractors

Contractors may be delegated by the District to perform the roles and responsibilities of the District to implement this policy.

4.4 Users

Users, to which this policy applies, as identified in Section 2.2, shall comply with all requirements listed in Section 5.0. Users shall permit inspections by the District with or without notice for the purpose of determining applicability and/or compliance with this policy.

5.0 Requirements

This section describes the requirements for all applicable users. Prior to purchasing a business or signing a lease for an existing retail space, it is recommended the user contact the District with questions about their requirements. This can help users avoid costly mistakes or oversights.

5.1 Plan Reviews

The user and owner of the property, business, or industry or an authorized representative of the user must contact the District for the purpose of obtaining a plan review. The plan review shall determine the need, size, location, and other requirements of the GGI required to control discharges. Written approval from the District must be obtained prior to installation of the GGI. The review of such plans and operating procedures shall in no way relieve the user from the responsibility of modifying such facilities as necessary to produce

a discharge acceptable to the District in accordance with this Policy and the Engineering Standards of the District.

Plans are required to be submitted for approval prior to any of the following:

- Sale or transfer of ownership of the business,
- Construction of a new building
- Change in the trade name under which the business is operated,
- Change in the nature of the services provided that affect the potential to discharge FOG, and/or
- Remodeling of the facility that may result in an increase in flow or FOG loading or that otherwise requires the facility to submit plans or specifications for approval through a building or zoning department, or any other formal approval process of a city, county, or other jurisdiction.

All plans submitted to the District must show the location of the GGI, clearly identify plumbing and plumbing fixtures that connect to the GGI, identify plumbing and plumbing fixture sizes, and a table or schedule identifying fixture flow (see Tables 1 and 2). Plans shall include proposed GGI size in accordance with the GGI sizing criteria provided in Section 5.2.2. Plans shall include a GGI detail showing internal plumbing, dimensions, cleanouts and vent piping. Construction shall not deviate from approved plans. If a situation warrants a change from approved plans, an amended copy must be resubmitted to the District for approval.

GGI installation and associated plumbing shall be inspected and approved by the District prior to backfilling.

5.2 GGI Design & Installation Criteria

5.2.1 GGI Plumbing and Structural Requirements

All sinks, floor drains, floor sinks, mop sinks, disposals, dishwashers and other plumbing fixtures in kitchens, bars, bussing stations, and other food service areas into which wastewater is likely to or has the potential to contain FOG must be connected to the GGI. Water closets, urinals, and other plumbing fixtures conveying human waste shall not drain into or through the GGI.

Each business establishment for which a GGI is required shall have a GGI serving only that establishment. Common or shared GGIs are only allowed under limited circumstances determined by the District on a case-by-case basis. If a GGI is used by more than one business, the property owner or property manager will be required to ensure the GGI is maintained in accordance with District requirements.

All GGIs and associated plumbing shall be installed by a licensed plumber or contractor. GGIs shall be installed in an accessible exterior location, have a minimum of five hundred (500) gallons capacity, and have a minimum of two (2) compartments separated by a baffle wall. The primary compartment shall have a volume equal to two thirds of the total capacity, and the secondary compartment shall have a volume equal to one third of the total capacity. Each compartment shall be accessible by a traffic rated manhole above the inlet and outlet piping with a minimum diameter of 24 inches. Manhole covers may not be locked, or otherwise fastened in place such that access is restricted.

All plumbing shall be compatible with food service wastewater, such as PVC. A sampling-T with a removable cap shall be placed at the outlet end of the GGI to allow sampling of effluent. The top of the sampling-T shall be no more than one foot below grade. In order to maximize retention time in the primary chamber, the bottom of the inlet piping shall extend down 25% of the total water depth. The bottom of the outlet piping must extend down between 9 and 12 inches of the base of the GGI. Flow from the primary to secondary compartment shall be through a 90° elbow bend, or similar device equivalent in cross sectional area to the inlet piping into the GGI, and shall extend down in the primary compartment of the GGI with a height above the base between 9 and 12 inches. Support brackets are required for inlet and outlet piping. Clean outs and venting shall be PVC. GGIs shall have two (2) vent pipes, one shall vent the body of the GGI and one vent pipe shall connect to the external effluent piping. Vent pipes shall remain independent to a location above finished grade, be independent of any other building venting system and shall be in accordance with local building codes. Refer to Exhibit 1 for a diagram of a GGI.

5.2.2 GGI Sizing

The sizing of the interceptor shall be determined by the District using Tables 1-3.. If the GGI is being sized for a vacant shell building, Table 3 shall be used to determine the GGI size.

If the sizing calculations indicate that a grease interceptor of less than 350 gallons is required, the District may determine a GGI does not need to be installed by the user. This determination will be made upon an initial review of plans and of the user's proposed operations. See Section 5.2.6 for more details.

Table 1: GGI Sizing Based on Fixture Flow

Fixture Type	Quantity	Fixture Surge Flow Rate (gpm)	Averaging Multiplier	Flow (gpm) = Quantity x Fixture Surge Flow Rate
Hand Sink		5	.25	
Bar Hand Sink		5	.25	
Single/Prep Compartment Sink		20	.25	
Double Compartment Sink		25	.25	
Triple Compartment Sink		30	.25	
Mop Sink		5	.25	
Wok Range (1-5 Wok Stations)		15	.25	
Wok Range (5+ Wok Stations)		20	.25	
Dishwasher (0-30 gallons)		15	.25	
Dishwasher (30-50 gallons)		25	.25	
Dishwasher (50-100 gallons)		40	.25	
Floor Drains		N/A ₁	----	N/A ₁
Other ₂			.25	
Total Flow (gpm)				
Loading Factor Coffee Shop - 0.5 Other Users ₃ = 1.0				
GGI Size (gallons) = Total Flow x Loading Factor x Retention Time				
GGI Inlet Pipe Size₄				
Maximum GGI Size (gallons)₅				

Notes:

- 1 Floor drains must be counted and connected to the GGI, but due to the frequency of their typical use, their surge flow rate is not included in the calculation.
- 2 The surge flow rate for plumbing fixtures not listed shall be based on manufacturer rating or drain pipe size in Table 2. If a fixture type is listed and the listed standard surge flow rate is larger than that provided by a manufacturer, the lower surge flow rate may be used. Documentation of and manufacturer rating used in the calculation shall be provided during the plan review.
- 3 The District may apply a loading factor other than 1.0 for users if special circumstances warrant.
- 4 Enter the maximum GGI size based on the inlet pipe size from Table 3.
- 5 If the calculated GGI size is greater than the maximum GGI size, the maximum GGI size shall be used.

Table 2: Surge Flow Rates Based on Fixture Discharge Pipe Size

Fixture Discharge Pipe Size (inches)	Surge Flow Rate (gpm)
1.25	7.5
1.5	15
2.0	22
2.5	30
3.0	37.5
4.0	45

Table 3: GGI Sizing for Unfinished Building Shells and Maximum GGI Size

GGI Inlet Pipe Size (inches)	GGI Size (gallons)
2	500
3	1,000
4	2,000
5	3,500
6	5,000

5.2.3 GGI Location

Each GGI shall be so installed and connected that it shall be at all times easily accessible for inspection, cleaning, pumping, and maintenance. Each GGI manhole cover shall be readily accessible and safely removable for servicing and maintaining the GGI in good working condition. The use of ladders, the removal of bulky equipment, or any other circumstances that impedes safe access in order to service or inspect GGIs shall constitute a violation of accessibility. GGIs are not permitted to be located in parking spaces or drive-thru lanes.. GGIs shall not be installed in any part of a building where food is handled. Location of all GGIs shall be shown on the approved building plan.

5.2.4 Common or Shared GGIs

Common or shared GGIs are not permitted unless a variance is granted. Any common or shared GGIs must be sized appropriately for each individual restaurant and the sizes must be added together to obtain the final GGI size. Common or shared GGIs may be reevaluated for proper sizing and capacity as facilities change business operations, practices, or owners or tenants.

5.2.5 Facilities with Existing GGIs

Some facilities may already have a GGI in place. An existing GGI may be undersized for a user according to the sizing requirements of Section 5.2.2. The District may approve a new user or a user who is required to submit plans for review under Section 5.1 to use the existing GGI if the District determines it can adequately protect the sanitary sewer from FOG. The existing GGI must have two chambers

and be retrofitted to meet the requirements of Section 5.2.1 and 5.2.2 if the original structure does not comply with the current sizing guidelines.

5.2.6 Determination of No GGI Required

If the District has determined that no GGI is to be installed, the user shall connect all plumbing fixtures listed in Section 5.2.1 to a sanitary sewer line separate from the domestic sanitary sewer line. This separate sanitary sewer line shall have a cleanout located outside of the building to allow the District access for sampling. The separate sanitary sewer line is designed to allow representative compliance sampling and installation of a GGI should one be required. This line may be combined with the domestic sanitary sewer at a point after the cleanout. If a facility's discharge exceeds the control authority's limit for oil and grease, or contributes to an excess build-up of FOG in the sanitary sewer line, the user may be required to install an appropriately sized GGI. The user may be charged for any fees associated with sampling, including labor costs, travel time, sampling supplies, and analytical costs.

5.3 GGI Maintenance & Operation

5.3.1 GGI Service & Maintenance

All users are required to structurally maintain all components of their GGI(s) as per the design requirements in accordance with Section 5.2.1 of this Policy. Additionally, GGIs shall be maintained, at the expense of the user, by regularly scheduled cleaning so that they will properly operate as intended to efficiently intercept the FOG from the user's wastewater and prevent the discharge of said materials into the City's wastewater collection system. A GGI shall be serviced at a minimum of every 90 days or more frequently as needed to ensure that the total depth of FOG and settled solids does not exceed twenty five percent (25%) of the GGI's total capacity or the capacity of an individual compartment. Biological treatment of enzyme treatment shall not be a substitute for the servicing of the GGI. Use of enzymes or any other products to emulsify FOG is prohibited. The direct addition of any enzyme, chemical, microbial agent to a GGI is prohibited

The District may allow a less frequent service schedule if the user can demonstrate the GGI does not need to be pumped every 90 days. Users seeking a modified service schedule shall complete and submit an application to the District demonstrating a less frequent service schedule is adequate. Applications will be reviewed by the District and written approval must be obtained from the District before any modified pumping schedule can be implemented.

Maintenance of GGIs shall be done in a workman like manner only by a business or professional normally engaged in the servicing of such plumbing fixtures. Users should ensure that companies used for the removal and transportation of grease waste are properly registered with the Colorado Department of Public Health and Environment. Partial removal of contents (i.e., removal of grease layer, oil layer or sludge layer) is not allowed. Contents removed from GGIs shall be hauled offsite

and disposed of properly. Under no circumstances shall GGI contents be reintroduced to the sanitary sewer system. The user must take reasonable steps to assure that all waste is properly disposed of at a facility in accordance with federal, state and local regulations (i.e. through a certification by the hauler included on the waste manifest or trip ticket for each load.) Users are responsible for the maintenance, servicing, and proper waste disposal and cannot abrogate this responsibility to a contractor, pumping service, or any other agent.

5.3.2 GGI Recordkeeping

All records, receipts, and manifests of GGI maintenance, removal of GGI contents and of offsite hauling of FOG waste including waste grease bin (WGB) contents shall remain onsite and accessible for review by the District for a minimum of three (3) years. The District may require a user that falls under the provisions of this policy to submit copies of all records, receipts, and manifests of GGI and/or WGB maintenance, removal of GGI and/or WGB contents and of offsite hauling of FOG waste.

5.3.3 GGI Non-Compliance

In the event a GGI is not properly maintained by the user, the District may authorize such maintenance work to be performed on behalf of the user. The costs of such maintenance shall be billed directly to the user and shall become part of the charges due and owing to the City and shall constitute a lien against the property until paid in full.

5.4 GGI Closure

The District may determine that a GGI is no longer necessary. This may occur when the wastewater flow through the interceptor is significantly lower due to changes in kitchen practices. A lack of flow through the GGI often causes the GGI to become septic producing noxious sulfide gases, serious odor problems, and other potential health and safety hazards. Inactive GGIs shall be closed by:

- The user must notify the District prior to closure of the GGI to allow for inspection;
- Submittal and approval of plans or a narrative to the District detailing the proposed scope of work;
- Complete removal of GGI contents (oil, grease, solids, water, etc.), performed by a professional grease interceptor service company,
- Sealing of all floor drains and fixtures plumbed to the GGI (if capping of GGI inlet and outlet pipes is required), or installation of a direct pipe connection from the inlet to the outlet,
- Filling of the empty GGI with an appropriate fill material such as sand, and
- Securing the opening(s) to the interceptor (e.g. cement, weld, etc.)

The District must approve plans or the narrative scope of work prior to beginning work. Inspections of closure activities are required by the District.

5.5 Hydro-mechanical Grease Interceptor (HGI) Requirements

Hydromechanical grease interceptors (HGIs) shall not be permitted in lieu of GGIs to comply with the requirements of this policy.

At the discretion of the District, certain facilities that do not have the potential to discharge excessive amounts of FOG shall be required to install an approved grease control device that meets the American Society of Mechanical Engineers (ASME) A112.14.3 Type C standard. In addition to the installation of a HGI, the user shall be required to establish a schedule of BMPs to minimize the discharge of FOG into the District's sanitary sewer system. Food service establishments that may be considered for this approach include establishments such as small sandwich shops and small bakeries that do not use flatware, do not utilize an automatic dishwasher, and do not have a garbage disposal. Sinks, plumbing fixtures in kitchens and other food service areas into which wastewater is likely to or has the potential to contain human waste shall not drain into or through the HGI.

All HGIs and associated plumbing shall be installed by a licensed plumber or contractor. All HGIs must be certified to the ASME A112.14.3 Type C standard. HGIs located outside and below-grade are required to be accessible by a traffic rated manhole cover(s). Manhole covers shall not be locked or otherwise fastened in place such that access is restricted. All plumbing shall be compatible with food service wastewater, such as PVC.

If a facility's discharge exceeds the District's limit for oil and grease or contributes to an excess build-up of FOG in the sanitary sewer line, the user may be required to install an appropriately sized GGI.

5.5.1 HGI Plan Review

Plan reviews for the installation of an approved HGI shall comply with the requirements of **Section 5.0**. Sizing of an approved HGI shall be based on the manufacturer's recommendations and the best professional judgment of the Control Authority. The minimum allowable HGI design flow rate shall be 50 gallons per minute.

Each HGI shall be installed and connected so as to be easily accessible at all times for inspection, cleaning, pumping, and maintenance. Each HGI cover shall be readily accessible and easily and safely removable for servicing, maintenance, and inspection. Location of all HGIs shall be shown on the approved building plan.

5.5.2 HGI Maintenance

Approved HGIs must be cleaned, maintained and inspected on a schedule not to exceed every 90 days. HGI pumping must be completed by a registered grease waste hauler.

5.6 Best Management Practices (BMPs)

The purpose of BMPs is to minimize the discharge of FOG into the District's sanitary sewer system. The following BMPs shall be implemented by nondomestic users to whom this policy applies. This includes employee training and kitchen practices that are essential in minimizing FOG discharges:

- **Installation of drain screens.** Drain screens shall be installed on all drainage pipes in food preparation areas. This includes kitchen sinks, floor drains and mop sinks. Drain screens shall be cleaned as needed.
- **Segregation and collection of waste cooking oil and grease.** All waste cooking oil and grease shall be collected and stored properly in waste grease bins (WGBs) or similar devices. WGBs shall be maintained to ensure that they do not leak and are weather tight. WGBs shall have a cover or lid which is to remain in place at all times when the WGB is not being used. WGBs shall be located in an area that is clean and easily accessible. WGBs shall be pumped before they are 90% full by a licensed waste hauler or an approved recycler to dispose of waste cooking oil.
- **Disposal of food waste.** Food wastes shall be disposed of directly into the trash or garbage and not in the drain.
- **Kitchen signage.** Signs shall be posted above all sinks prohibiting the discharge of oil, grease, and food waste down the drains.
- **Employee training.** Employee training shall be provided as part of the normal orientation process and annually thereafter including, at a minimum, the following subjects:
 - How to scrape excess food into the garbage and “dry wipe” pots, pans, dishware and work areas before washing to remove grease,
 - The location, use, and disposal of absorption products to clean any spills under fryer baskets and other locations where grease may be spilled or dripped,
 - How to properly dispose of grease or oils from cooking equipment into a grease receptacle without spilling,
 - The need for and cleaning of drain screens, and
 - Proper cleanup techniques of cleaning product or other chemical spills, if safe to do so.

Training shall be documented and employee signatures retained indicating each employee's attendance and understanding of the practices reviewed. Training records shall be made available for review at any reasonable time by the District.

5.7 Spill Prevention

All users are required to have measures in place to control unwanted discharge to the sanitary sewer. Chemicals, cooking oils, and other liquid products must be stored away from drains or within a containment to reduce the potential for spills reaching the sanitary sewer and/or storm drainage system.

5.8 Variances

A variance to the requirements of this policy for existing users may be granted by the District for good cause. The user has the burden of proof of demonstrating through data and other information why a variance should be granted. In no case shall a variance result in a violation of any requirement or effluent limit specified in the City of Littleton Municipal Code. The granting of any variance shall be at the discretion of the District and requires the approval of the Division.

If a variance is granted, the user shall institute BMPs and other mitigation measures as determined by the District.

6.0 Enforcement

The District has the authority to enforce the requirements specified herein. Upon inspection of a user's GGI and/or BMPs, the user will be given a copy of the inspection form. The inspection form will contain the inspection results and will indicate the deadline for any corrections if necessary.

Required time frames for violations are as follows:

- Repairs to grease removal device must be completed within fifteen (15) calendar days;
- Pumping requirements must be completed with five (5) calendar days;
- Missing drain screens and WGBs must be replaced within ten (10) calendar days;
- Spills or leaks around WGBs shall be cleaned-up within 24 hours;
- Missing kitchen signage must be immediately replaced;
- Violations involving improper employee BMP adherence shall require retraining of the employee and documentation of such training to be post marked, hand delivered, or emailed to District within five (5) calendar days; and
- Records, receipts and/or manifests of GGI and WGB maintenance not available for review upon inspection must be provided to the District with five (5) days.

If a user fails to make the corrections within the allotted timeframe, the user will be referred to the enforcement authority. Fines and/or re-inspection fees may be levied as an enforcement action. If non-compliance continues the enforcement authority may escalate enforcement actions that could include both civil and criminal actions. The District and the City have the authority to perform work or hire a contractor to perform work necessary to bring a user into compliance. Costs associated with work including labor, equipment, and materials incurred in rectifying the non-compliance shall be billed directly to the user and the total charges due shall constitute a lien on the user property until paid in full.

7.0 References

Englewood Municipal Code: Title 12, Chapter 2, Section 5

Littleton Municipal Code: Title 7, Chapter 5, Section 25

Colorado Department of Health and Environment Waste Grease Regulations 6 CCR 1007-2 Part 1 Section 18 <http://www.colorado.gov/cs/Satellite/CDPHE-HM/CBON/1251616361896>

S:\data\WPDOCS\DOCUMENTS\Word Files\PC FOG Policy.docx
Revised: 9/26/2017

EXHIBIT 1

HIGH RATE - DUAL COMPARTMENT

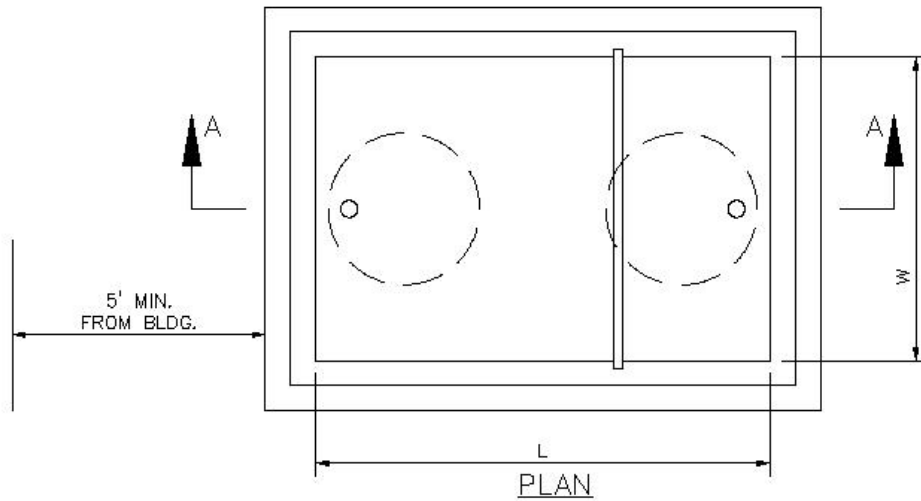

VENT "A" MAY RISE A MINIMUM OF 42" ABOVE FIXTURE FLOOD LINE AND MAY COMBINE WITH VENT "B" ABOVE THE 42" LINE TO FORM A SINGLE VENT THROUGH THE ROOF.

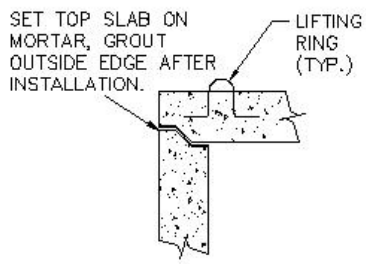
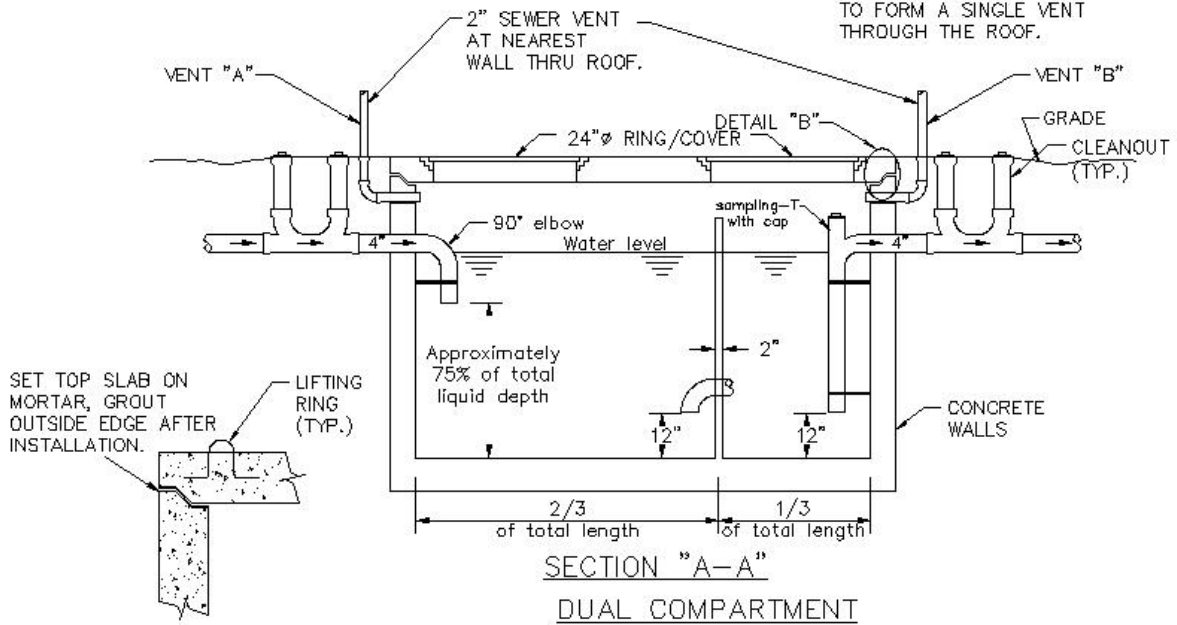

DETAIL B